



ASSEMBLY AND OPERATING INSTRUCTIONS

Automatic electric barrier

ES3500



Please read this manual before using the product and follow the instructions it contains!

GENERAL

Foreword	3
Definition	3
Safety instructions	5
Technical data	5
Overview of the main components	6
Assembly instruction	7
Installation of loop sensor for crash protection	7
Installation of the LED barrier boom	8
Operating instructions	10

MAINTENANCE

Checklist for maintenance / inspection	16
Troubleshooting	17
Error codes	17
Service & contact	17
UKCA Declaration of Conformity	18

FOREWORD

Congratulations on the purchase of your new electric barrier. The ES3500 has been manufactured from high quality materials, specifically designed for durable and reliable use. For your own safety and to ensure correct operation of the electric barrier, be sure to read and follow these operating instructions before using it.

Keep these operating instructions. Check the ES3500 for transport damage. Damaged electric barriers must not be pulled into use. The ES3500 is used for the temporary obstruction of travel paths.

Improper handling may result in injury or damage to the ES3500. Any liability for damages resulting from the improper use of the barrier device or the disregard of specifications and rules of conduct of this operating manual is excluded.

The operator is responsible for ensuring correct use by trained and authorized personnel.

DEFINITION

AUTHORIZED PERSON

Trained and assigned personnel who use this device, prepare and suit it for the job, and provide adequate instruction to operators. These instructions refer to, among other things:

1. Mechanics and auxiliary equipment of the device
2. Electrics and electronics of the device
3. Maintenance of lubrication
4. Protective devices and accident prevention measures
5. Obligatory tasks of the setter

OPERATOR

Trained personnel authorized by the authorized person to use this device for, among other things, safe use, setup, trial runs, maintenance, cleaning, while avoiding all hazards. Hazards include, but are not limited to, use in the wrong environment, failure to wear PPE or inappropriate PPE, inadequate testing, and improper use.

INTENDED USE

Use this device in accordance with the information provided in these operating instructions.

DEVICE

This electric barrier, with accessories.

BARRIER BOOM

Exclusively the barrier rod, which is attached to the electric motor and moves up and down.

PPE

Personal protective equipment, such as hard helmets, safety shoes, protective gloves, protective clothing, etc.





REASONABLY FORESEEABLE MISAPPLICATION

Use of this device in a manner not intended by the constructor, but which may result from readily foreseeable human behavior.

TARGET GROUP

Group of persons intended by the manufacturer for these operating instructions (authorized person, operator).

USED MARKINGS

Image	Category	Explanation
	Warning	Attention. Barrier boom coming down
	Warning	Avoid passage of bicycles. Please dismount
	Prohibition	Do not stand under the barrier
	Warning	Do not park your vehicle under the barrier

SAFETY INSTRUCTIONS

- First check the equipment for transport damage. Damaged devices must not be pulled into operation.
- As the authorized person, instruct all operators in the safe use of the device.
- Do not bypass any safety-related equipment of the device.
- Do not remove any safety labels from the device. Worn warning labels and safety signs must be replaced immediately.
- Only adults who are in full possession of their physical and mental faculties may operate the barrier system.
- Do not park any vehicles below the barrier boom. No persons, objects or animals may be in the driving range of the barrier boom when driving up or down.
- Do not reach into the travel range of the barrier boom or into the moving parts of the drive.
- Do not drive through the path / road until the barrier boom is fully raised.
- The gate / barrier system must be secured according to its use in compliance with the applicable standards and guidelines.
- Only operate the remote control when you have a complete view of the travel range of the barrier boom. Ensure that no objects, persons or animals are in the travel range.
- Store the remote control in such a way that unintentional activation is impossible.
- Only use the radio remote control in locations that are insensitive to radio interference.
- Carry out regular maintenance and servicing measures in accordance with these operating instructions.
- Switch off the device and disconnect it from the power supply before carrying out maintenance and servicing measures.
- Observe the operating temperature range of the device of - 30 °C - + 80 °C.
- Set up the device in a location that is as protected from the weather as possible.
- Anchor the device firmly to the ground to prevent it from tipping over and moisture from penetrating from the ground.
- Use the enclosed bolt anchors for this purpose.
- Do not modify or alter the device without the written consent of the manufacturer. Non-compliance will result in the exclusion of all warranty provisions.

TECHNICAL DATA

GENERAL

Type	Unit	Value
Model		ES3500
Dimensions	mm	355 x 245 x 1040
Net weight	kg	35
Max. barrier length	mm	3500
Color barrier		White red
Color housing		Grey
Movement duration	s	1.8 – 3
Working temperature	°C	-30 – +80
Humidity	%	90
Optional		App control

ELECTRICS

Type	Unit	Value
Rated voltage	V	24
Mains voltage	V	230
Rated power	W	100
Protection class		IP54

REMOTE CONTROL

Type	Unit	Value
Range	m	30
Frequency	MHz	430.5

OVERVIEW OF THE MAIN COMPONENTS

No.	Designation
1	Keyhole
2	Housing cover
3	Barrier boom
4	Warning and safety signs
5	Radio antenna
6	Gear shaft
7	Transmission shaft

No.	Designation
8	Limit sensor
9	Drive shaft
10	Gear and engine
11	Open
12	Stop
13	Close
14	Keychain

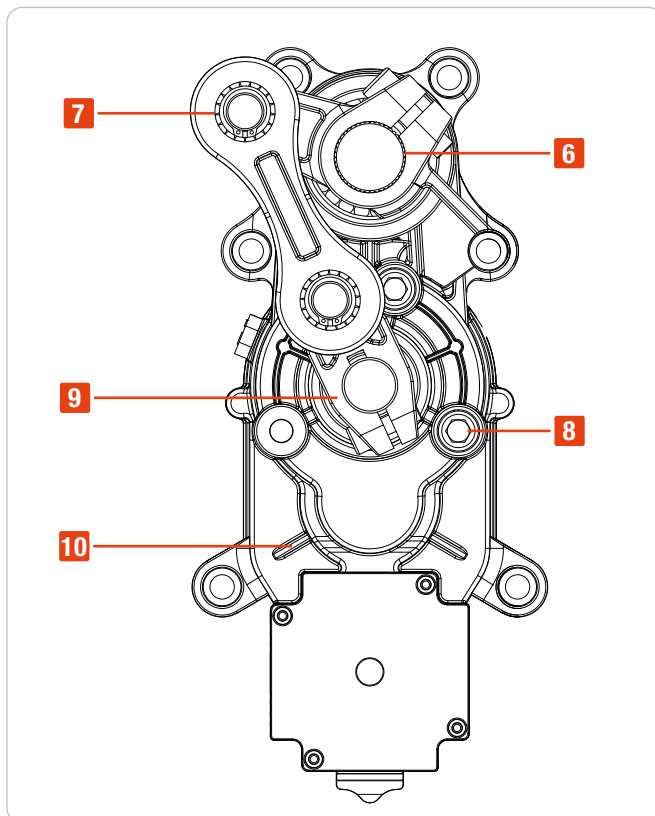

ASSEMBLY INSTRUCTION

BEFORE ASSEMBLY

- Before assembly, check all components for transport damage and for completeness.
 - Connect the barrier before mounting and check the direction of rotation to determine the alignment of the barrier boom and housing.
 - Test the surface before mounting. It must be a flat, solid surface.
1. Mount the housing at the desired location next to the road or path. Use the enclosed bolt anchors for this purpose.
 2. Measure the barrier boom and screw the enclosed self-tapping metal screw into the boom. A cordless screwdriver with a Torx bit is required for this. If the barrier boom is completely pulled out, you can also use the pre-drilled holes.
 3. Mount the barrier arm on the housing according to the illustration. Use the enclosed screws with hexagon head for this purpose.

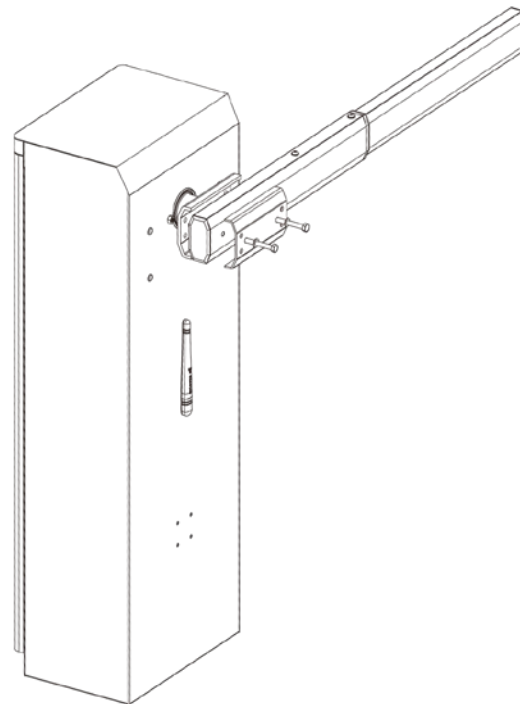

INSTALLATION OF LOOP SENSOR FOR CRASH PROTECTION



Before installation, switch off the device and disconnect it from the power supply if possible. Only allow qualified personnel to carry out electrical modifications.

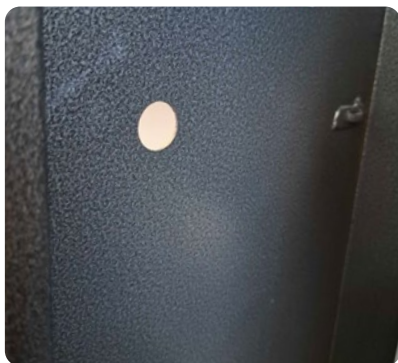

1. Knock out one of the round recesses on the side where the barrier comes down. Use a suitable tapping tool for this.



2. Completely unscrew the wing nut from the loop sensor
3. Insert the cables from the outside through the recess that has been removed.
4. Screw the wing nut back on from the inside.



5. Connect the cables as follows:
 - Black power cable to COM
 - Red power cable to +24V
 - Orange signal cable to Loop
 - Blue signal cable to GND (ground))
6. Securely stow the remaining cables in the housing
7. Switch the barrier back on and close the housing before operation.



The loop sensor ensures that the barrier cannot be closed when it is in the open position and an object (a person or a vehicle) is within the detection range of the loop sensor.

INSTALLATION OF THE LED BARRIER BOOM

1. Install the barrier boom according to the illustration on page 25 of this installation manual.
2. Insert the telescopic arm into the first section of the barrier boom as far as required. Fix the telescopic arm at the desired position using the self-tapping metal screw.



3. Connect the cable for the LED strip.

4. Shorten the LED strip at a marked position. Then attach the LED strip to the telescopic arm.



5. Cut the plastic sleeve to the appropriate length to fit the telescopic arm. Then thread the plastic sleeve onto the telescopic arm.

6. Close the barrier boom with the end piece.

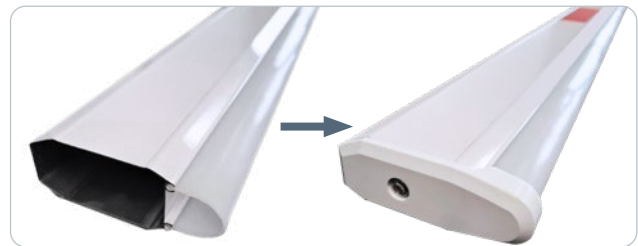

7. Connect the cables according to this diagram:

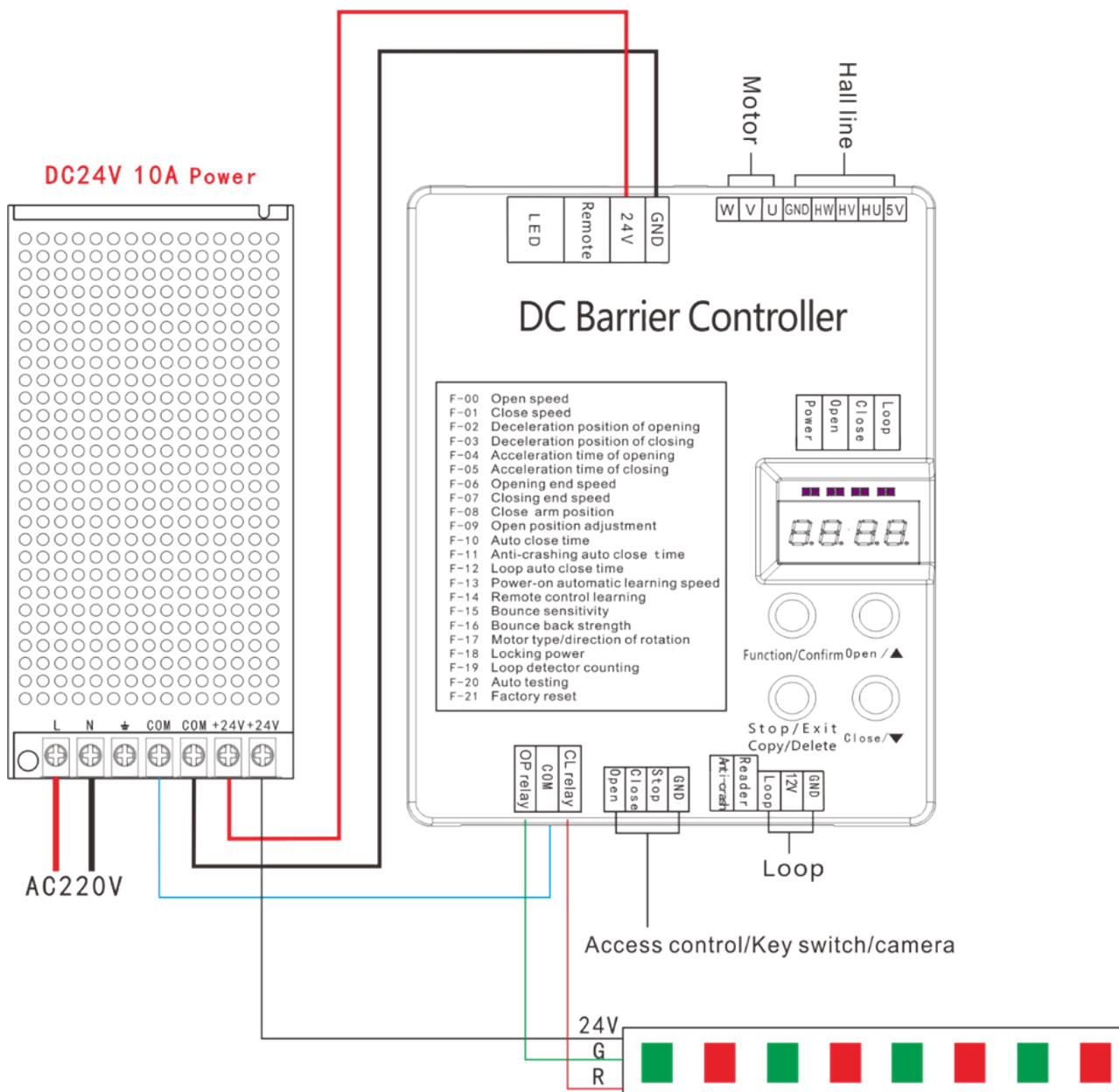

OPERATING INSTRUCTIONS

SETTING UP THE APP CONTROL

1. Download the Tuya Smart app.
2. Open the app on your smartphone and register.
3. Activate Bluetooth on your smartphone.
4. Connect the electric gate to the power supply.
5. Open the front cover of the electric gate.
6. Press the reset button on the Tuya Smart Switch for five seconds. The device will start to flash. The frequency of your Wi-Fi router must be 2.4 GHz.
7. Tap on the plus sign in the top right corner of the app and then on 'Add device'. The search via Bluetooth will start. Add the device that is close to you. The device will automatically connect to the Wi-Fi network that your end device is currently connected to.
8. Press 'All off' in the bottom right corner to reset all the barrier settings.

ADJUSTMENTS WITHIN THE APP

1. Long press on 'Switch x' to rename the respective function.
2. Press 'Timer' to program timers. Automatic opening and closing times can be programmed here.



After pairing, you can control the electric gate regardless of which Wi-Fi network you are in.

PASSING ON ACCESS RIGHTS VIA THE APP

1. Open the Tuya Smart app on your smartphone or tablet.
2. Select the device in your app.
3. Press the options icon in the upper right corner.
4. Press 'Share device'.
5. Select the method for sharing. You can share access rights via email, account, or link.
6. The other account accepts the sharing.



Rights such as adding or removing access rights to the device remain with the admin account.

REMOVE ACCESS RIGHTS VIA APP

1. Open the Tuya Smart app on your smartphone or tablet.
2. Select the device in your app.
3. Press the options icon in the upper right corner.
4. Press 'Share device'.
5. Click the hexagon in the upper right corner.
6. Press the account you want to remove.
7. Press 'Stop sharing' and confirm.

DAILY OPERATION

- To raise: Press the button to open the barrier boom (11).
- To lower: Press the button to close the barrier boom (13).
- In dangerous situations, press the Stop button (12) to stop the barrier boom during movement.
- Then press Open (11) or Close (13) to return it to a neutral position.



Observe the travel path of the barrier boom when raising or lowering it. If there are objects, persons or animals in the travel path, the barrier boom must not be moved, as this would result in a collision.

ILLUSTRATION OF THE WIRING AND CONTROL MODULE

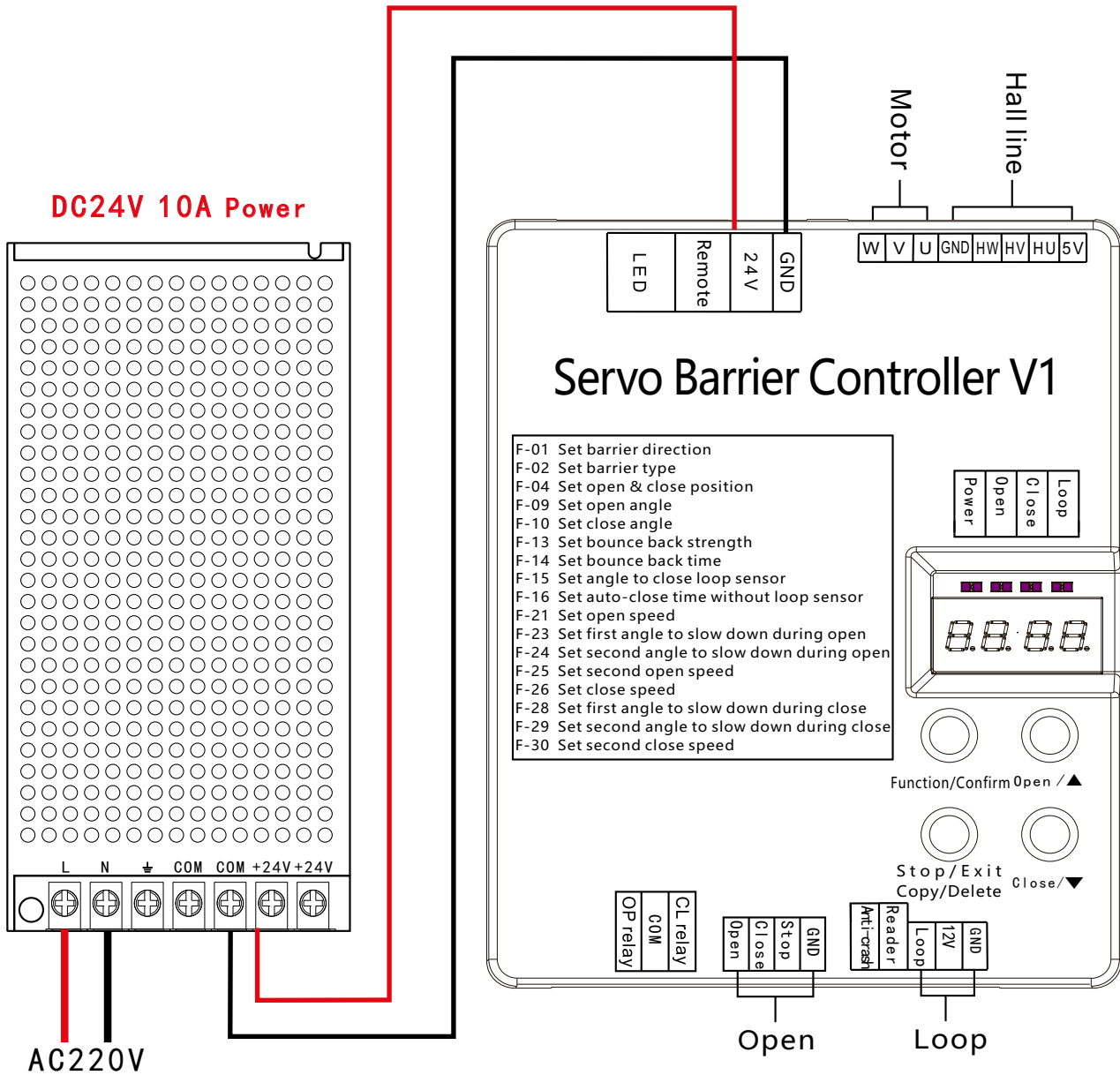

In the event of a power blackout, the barrier automatically returns to the opened position. Do not change this factory setting as it represents a safety-related function.

CHANGING THE PARAMETER SETTINGS



In the fewest cases it is necessary to adjust the parameter settings. Change them only if there is no other solution or the device has been adjusted. The factory settings are sufficient for most applications.

CHANGING THE OPENING DIRECTION OF THE BARRIER

- Press the „Function / Save“ button for 3 seconds to access the parameter settings.
- Use the „Open“ and „Close“ buttons to select the setting F-01 and confirm the entry with the „Function / Save“ button.
- Increase the value with the „Open“ button. Decrease the value with the „Close“ button.
- Changing the value changes the button assignment on the remote control. The value 01 lowers the barrier on the left and the value 02 lowers it on the right.
- Press the „Confirm / Stop / Copy / Delete“ button to confirm the entry.
- Press the „Function / Save“ button for several seconds to exit the menu.

CHANGING THE CLOSING AND OPENING POSITION

- Press the „Function / Save“ button for 3 seconds to access the parameter settings.
- Use the „Open“ and „Close“ buttons to select the setting F-04 and confirm the entry with the „Function / Save“ button.
- Increase the value with the „Open“ button. Decrease the value with the „Close“ button.
- Set to 01 and press „Function / Save“. Press „Open“ to start the automatic calibration.
- Set to 02 and press „Function / Save“. Press „Open“ and „Close“ to manually set the opening position.
- Press „Function / Save“ again to manually set the closing position in the second step.
- Press the „Confirm / Stop / Copy / Delete“ button to confirm the entry.
- Press the „Function / Save“ button for several seconds to exit the menu.

CHANGING THE OPENING ANGLE

- Press the „Function / Save“ button for 3 seconds to access the parameter settings.
- Use the „Open“ and „Close“ buttons to select the setting F-09 and confirm the entry with the „Function / Save“ button.
- Increase the value with the „Open“ button. Decrease the value with the „Close“ button.
- The smaller the set value, the greater the angle between the position of the barrier arm and the vertical position when opening.
- Press the „Confirm / Stop / Copy / Delete“ button to confirm the entry.
- Press the „Function / Save“ button for several seconds to exit the menu.

CHANGING THE RESET STRENGTH

- Press the „Function / Save“ button for 3 seconds to access the parameter settings.
- Use the „Open“ and „Close“ buttons to select the setting F-13 and confirm the entry with the „Function / Save“ button.
- Increase the value with the „Open“ button. Decrease the value with the „Close“ button.
- The smaller the value, the more sensitive the reset on impact.
- Press the „Confirm / Stop / Copy / Delete“ button to confirm the entry.
- Press the „Function / Save“ button for several seconds to exit the menu.

CHANGING THE RESET TIME

- Press the „Function / Save“ button for 3 seconds to access the parameter settings.
- Use the „Open“ and „Close“ buttons to select the setting F-14 and confirm the entry with the „Function / Save“ button.
- Increase the value with the „Open“ button. Decrease the value with the „Close“ button.
- The higher the set value, the faster the barrier boom opens after hitting an obstacle.
- Press the „Confirm / Stop / Copy / Delete“ button to confirm the entry.
- Press the „Function / Save“ button for several seconds to exit the menu.

CHANGING THE AUTOMATIC CLOSING TIME

- Press the „Function / Save“ button for 3 seconds to access the parameter settings.
- Use the „Open“ and „Close“ buttons to select the F-16 setting and confirm the entry with the „Function / Save“ button.
- Increase the value with the „Open“ button. Decrease the value with the „Close“ button.
- The lower the set value, the shorter the automatic closing time. If the value is zero, the barrier remains open until the close button (13) is pressed.
- Press the „Confirm / Stop / Copy / Delete“ button to confirm the entry.
- Press the „Function / Save“ button for several seconds to exit the menu.

CHANGING THE OPENING SPEED

- Press the „Function / Save“ button for 3 seconds to access the parameter settings.
- Use the „Open“ and „Close“ buttons to select the setting F-21 and confirm the entry with the „Function / Save“ button.
- Increase the value with the „Open“ button. Decrease the value with the „Close“ button.
- The higher the set value, the faster the barrier boom opens.
- Press the „Confirm / Stop / Copy / Delete“ button to confirm the entry.
- Press the „Function / Save“ button for several seconds to exit the menu.

CHANGING THE BRAKE POSITION WHEN OPENING

- Press the „Function / Save“ button for 3 seconds to access the parameter settings.
- Use the „Open“ and „Close“ buttons to select the setting F-23 and confirm the entry with the „Function / Save“ button.
- Increase the value with the „Open“ button. Decrease the value with the „Close“ button.
- The higher the set value, the shorter the distance of the slower end speed when opening.
- Press the „Confirm / Stop / Copy / Delete“ button to confirm the entry.
- Press the „Function / Save“ button for several seconds to exit the menu.

CHANGING THE ACCELERATION POSITION WHEN OPENING

- Press the „Function / Save“ button for 3 seconds to access the parameter settings.
- Use the „Open“ and „Close“ buttons to select the F-24 setting and confirm the entry with the „Function / Save“ button.
- Increase the value with the „Open“ button. Decrease the value with the „Close“ button.
- The higher the set value, the longer the distance of the slower start speed when opening.
- Press the „Confirm / Stop / Copy / Delete“ button to confirm the entry.
- Press the „Function / Save“ button for several seconds to exit the menu.

CHANGING THE FINAL SPEED WHEN OPENING THE BARRIER BOOM

- Press the „Function / Save“ button for 3 seconds to access the parameter settings.
- Use the „Open“ and „Close“ buttons to select the setting F-25 and confirm the entry with the „Function / Save“ button.
- Increase the value with the „Open“ button. Decrease the value with the „Close“ button.
- The higher the set value, the higher the final opening speed.
- Press the „Confirm / Stop / Copy / Delete“ button to confirm the entry.
- Press the „Function / Save“ button for several seconds to exit the menu.

CHANGING THE CLOSING SPEED

- Press the „Function / Save“ button for 3 seconds to access the parameter settings.
- Use the „Open“ and „Close“ buttons to select the setting F-26 and confirm the entry with the „Function / Save“ button.
- Increase the value with the „Open“ button. Decrease the value with the „Close“ button.
- The higher the set value, the faster the barrier boom closes.
- Press the „Confirm / Stop / Copy / Delete“ button to confirm the entry.
- Press the „Function / Save“ button for several seconds to exit the menu.

CHANGING THE BRAKE POSITION WHEN CLOSING

- Press the „Function / Save“ button for 3 seconds to access the parameter settings.
- Use the „Open“ and „Close“ buttons to select the setting F-28 and confirm the entry with the „Function / Save“ button.
- Increase the value with the „Open“ button. Decrease the value with the „Close“ button.
- The higher the set value, the longer the distance of the slower final speed when closing.
- Press the „Confirm / Stop / Copy / Delete“ button to confirm the entry.
- Press the „Function / Save“ button for several seconds to exit the menu.

CHANGING THE ACCELERATION POSITION WHEN CLOSING

- Press the „Function / Save“ button for 3 seconds to access the parameter settings.
- Use the „Open“ and „Close“ buttons to select the setting F-29 and confirm the entry with the „Function / Save“ button.
- Increase the value with the „Open“ button. Decrease the value with the „Close“ button.
- The higher the set value, the longer the distance of the slower start speed when closing.
- Press the „Confirm / Stop / Copy / Delete“ button to confirm the entry.
- Press the „Function / Save“ button for several seconds to exit the menu.

CHANGING THE FINAL SPEED WHEN CLOSING THE BARRIER BOOM

- Press the „Function / Save“ button for 3 seconds to access the parameter settings.
- Use the „Open“ and „Close“ buttons to select the setting F-30 and confirm the entry with the „Function / Save“ button.
- Increase the value with the „Open“ button. Decrease the value with the „Close“ button.
- The higher the set value, the higher the final closing speed.
- Press the „Confirm / Stop / Copy / Delete“ button to confirm the entry.
- Press the „Function / Save“ button for several seconds to exit the menu.

REMOTE CONTROL COUPLING

- Press the „Copy“ button until the LED display shows 1.
- Press any button on the remote control. The pairing is complete.
- This can be done with any number of remote controls. There are 2 for each electric barrier as standard.
- Press the „Function / Save“ button to exit the menu.

DELETE REMOTE CONTROL SETTINGS

- Press the „Copy“ button for 5 seconds until the LED display shows 0000.
- All remote controls have been removed.

CHANGING THE BARRIER CLOSING DIRECTION



This procedure is only necessary if the barrier arm is to move up and down on the other side. If you carry out the procedure without turning the barrier boom, this can damage the electric barrier.

1. Disconnect the electric barrier from the power supply.
2. Remove the barrier boom.
3. Open the front cover to gain direct access to the motor.
4. Loosen the two hexagon socket screws on the gear shaft (6). A size 8 hexagon key is required for this.
5. Turn the barrier boom suspension 90° by hand.
6. Tighten the hexagon socket screws that you loosened earlier.
7. Reconnect the electric barrier to the power supply.
8. Change the button assignment on your remote control. You will find a detailed description under 'Changing the opening direction of the barrier'.
9. Install the barrier boom as described in the instructions.

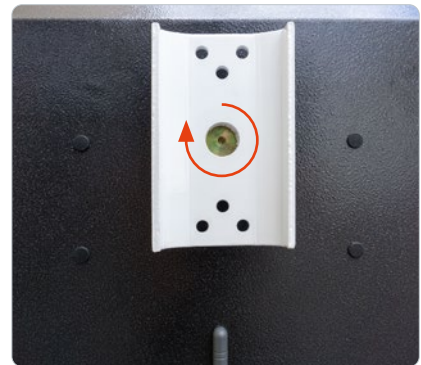

To change the direction of motor rotation and thus the opening direction of the barrier, mechanical adjustments to the motor itself are necessary. These should only be carried out by a specialist.

FACTORY SETTINGS CONTROLLER

Function	Value	Description	Setting
F-01	01	Set barrier direction	01 → Left 02 → Right
F-02	00	Set barrier type	01 → Brushless DC motor
F-03	41	Set motor type	00 → The motor rotates clockwise 01 → The motor rotates counterclockwise
F-04	33	Setting the opening and closing position	00 → Automatic learning of the opening position 01 → Automatic learning of the closing position 02 → Manual adjustment of the position
F-05	00	Limit value for fine tuning	Limit value for fine tuning
F-06	00	Not assigned	
F-07	00	Mode of the relay output	00 → HL Output traffic light signal 01 → HL Output local input signal 02 → L Level on site Signal 03 → H Alarm output
F-08	00	Test mode	00 → Normal mode 01 - 08 → Automatic test interval Display parameters Switch off and exit. Save parameters Switch off memory. The test interval corresponds to 1 - 8 s. 09 → 45° and 90° cross test
F-09	90	Set opening angle	00 - 99 degree
F-10	30	Set closing angle	00 → 30 - 6° to 0° 30 → 99 0° to 13,6°
F-11	00	Determining the 0° position	00 → Manually to find the 0° position 01 → Automatic to determine the 0° position
F-12	05	Current of the locking barrier	00 → Locking function off 00 - 20 Blocking current „10 - 15“ is recommended
F-13	70	Setting the reset strength	00 - 99 → The current that bounces back when it hits a resistor
F-14	09	Setting the reset time	00 - 99 Reset time
F-15	20	Setting the angle for closing the loop sensor	00 - 99 → 0 - 99°
F-16	00	Set time for automatic closing	00 → Function off 01 - 99 → delay 1 - 99 s until closing
F-17	20	Shielding angle when opening	Reset shielding angle when opening
F-18	20	Shielding angle when closing	Reset protection angle when closing
F-19	55	Light control	Light control

Function	Value	Description	Setting
F-20	10	Motor starting speed	
F-21	80	Set opening speed	
F-22	20 (0.1 s)	Acceleration time when opening	
F-23	50	Setting the first angle for braking when opening	
F-24	00	Setting the second angle for braking when opening	
F-25	01	Setting the second opening speed	
F-26	80	Setting the closing speed	
F-27	20 (0.1 s)	Acceleration time when closing	
F-28	50	Setting the first angle for braking during closing	
F-29	00	Setting the second angle for braking during closing	
F-30	01	Setting the second closing speed	
F-31	00	Minimum speed when opening	
F-32	00	Minimum speed when closing the door	
F-33	95	Maximum permissible speed	
F-34	42	Nominal speed of the motor	
F-35	10	Initialization speed	
F-36	30	Opening speed in the event of a power failure	
F-40	00	Loop direction of the delay	00 - 99 s loop guidance delay closing time
F-41	00	Normally open mode	0 → function off 1 → function off The fourth button on the remote control. Press and hold the stop button for 5 seconds
F-99	XX	Factory settings	XX display software version 00 → restore factory settings



Reset the device completely to the factory settings if the reason for a malfunction can no longer be determined.

CHECKLIST FOR MAINTENANCE / INSPECTION

		Interval		
		Monthly	Semiannual	Annual
1	Cleaning the housing	•		
2	Cleaning of the barrier boom	•		
3	Clean the interior of the housing and check for damage / rust	•		
4	Check cabling		•	
5	Check motherboard		•	
6	Check mechanics		•	
7	Check barrier boom for damage		•	
8	Check by an electrician			•

TROUBLESHOOTING

Problem	Cause	Solution
The barrier wobbles when it is in the open or closed position	Screws are loose	Open the housing and check the screws. Tighten loose screws
	Spring is too loose, too tight or broken	Adjust the spring properly or replace it
The barrier does not move or stops at the wrong position	The motor is overheated	Place the barrier in a location where there is not extreme heat. If the heat is too high, the motor goes into a protection mode against overheating
	Mainboard has been damaged	Replace the mainboard
	The barrier has hit an obstacle, causing the endpoint to be misaligned	Perform a reset. Please refer to the chapter operating instructions
The barrier opens or closes automatically	The cables connecting the endpoint sensor to the controller have become loose.	Check the cabling and restore the connections
	Short circuit	Have the cabling checked by an electrician
	Mainboard has been damaged	Replace the mainboard
	The magnet for the end point sensor is not in the correct position	Adjust the position of the magnet

ERROR CODES

Error code	Description	Solution
E1	Motor error	1. Check motor UVW line 2. Check Moto HU HV Hall line 3. Replace damaged motor
E2	Error in the encoder	
E4	Undervoltage error	Replace the high-voltage power supply unit
E5	Overcurrent error	Gearwheel damaged

SERVICE & CONTACT

Contact our product experts and find help and solutions for your product. Here you will find all contact information listed by country and language: www.topregal.com/en/service

Responsible for the content:
TOPREGAL GmbH
Industriestrasse 3
70794 Filderstadt
GERMANY
www.topregal.com

UKCA Declaration of Conformity

The manufacturer

TOPREGAL UK Ltd.
Carlton Drive Crumlin
Gwent NP11 4EA

hereby declares that the following product

Product name:

TecMaschin
Automatic electric barrier

Type:

ES3500

Serial number:

ES3500-1000000000 – ES3500-9999999999

that the equipment is in conformity with the following relevant UK legislations and applied standards:

2014/30/EU Electromagnetic compatibility

EN 55032

EN 55024

EN 61000-3-2

EN 61000-3-3

Name and address of the person who is authorized, compile the technical documentation:

TOPREGAL UK Ltd.
Carlton Drive Crumlin
Gwent NP11 4EA



Place: Crumlin UK
Date: 21.12.2022

Juergen Effner
Chief Executive Officer

TOPREGAL

TOPREGAL

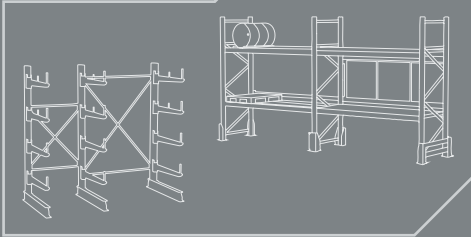

SolidHub



WIPEKET

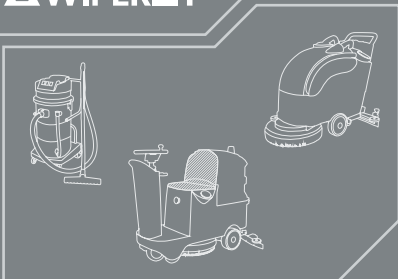

TECMASCHIN

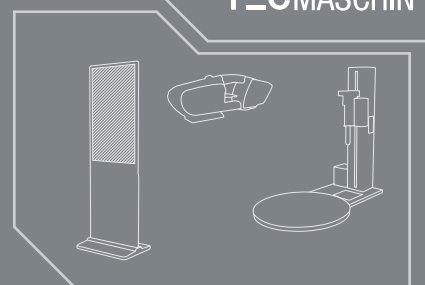

SOLOPORT

