



## INSTRUCTIONS MANUAL

Hydraulic jack

WH50



Please read this manual before using the product and follow the instructions it contains!

## GENERAL

Foreword	3
Safety warnings	3
Technical data	3
Overview of the main components	4
Safety devices and warning signs	4
Assembly instructions	5
Operating instructions	5

## MAINTENANCE

Maintenance and inspection	6
Troubleshooting	6
Parts list	7
Service & Contact	9
EU Declaration of Conformity	10

## FOREWORD

Congratulations on the purchase of your new hydraulic jack. The WH50 has been manufactured from high quality materials, specially designed for durable and reliable use. For your own safety and to ensure correct operation of the hydraulic jack, be sure to read and follow these operating instructions before using it.

Keep these operating instructions. Check the WH50 for transport damage. Damaged jacks must not be put into use.

The WH50 is used for lifting vehicles up to a weight of 110,231 lbs, by means of pneumatic-hydraulic pressure. Improper handling may result in injury or damage to the machine. The liability for damage resulting from improper use of the device or failure to observe the specifications and rules of conduct contained in this operating manual is excluded. The operator / user must ensure the correct use of the WH50 by trained and authorized personnel.

## SAFETY WARNINGS

- Only trained personal who have read and understood the operation with this jack and the operating procedures. The owner and operator shall be aware that use and maintenance of this product may require special skills and knowledge.
- This is a lifting device only.
- Only mentally and physically healthy adults are permitted to work with the jack.
- Be sure to check the device for transport damage and leaks before using it.
- The jack is intended exclusively for lifting vehicles. Never move vehicles with the WH50.
- After lifting, place undercarriage blocks under the vehicle to secure it.
- Never lie under a vehicle that is only lifted with the jack.
- Do not overload the jack. This is designed exclusively for tonnages up to 110,231 lbs. When using the small underlay block, this weight is reduced to 55,115 lbs.
- Only lift the vehicle at the specified pick-up points.
- Only use the jack on a level, horizontal surface that has sufficient strength.
- Before lifting, apply the handbrake of the vehicle, set the wheels straight and secure it with wheel chocks.
- Wear appropriate work and protective clothing when using the jack.
- Store the jack in a dry, frost-protected environment when not in use for a longer period of time.
- Only use suitable hydraulic oil.
- When lowering the jack, make sure that there are no objects or people under the vehicle.
- Do not expose the jack to media that promote corrosion.

## TECHNICAL DATA

Type	Unit	Value
Dimensions	"	11.22 x 21.25 x 47.24
Weight	lbs	130.07
Max. traction weight	lbs	110,231
Cylinder height	"	7.68 - 12
Max. lifting height	"	16.54
Lifting speed	s	17
Lowering speed	s	9
Air inlet diameter	"	0.35
Air inlet length	"	0.79
Air pressure	bar	8
Oil tank	fl oz	57.48
Roller diameter	"	7.09

## OVERVIEW OF THE MAIN COMPONENTS

No.	Name
1	Control lever
2	Drawbar lever
3	Drawbar
4	Lifting cylinder
5	Handle
6	Air inlet valve
7	Wheel
8	Underlay block



## SAFETY DEVICES AND WARNING SIGNS

No.	Name
9	Filter instructions
10	Weight data





## ASSEMBLY INSTRUCTIONS

1. Insert the hoses into the valve openings. The hose, with the smaller diameter, is inserted in the center. The other two hoses are distributed to the other two openings.
2. Place the drawbar on the drawbar bracket.
3. Push the fastening bolts through the openings to fix the drawbar.
4. Slide the retaining rings over the bolts to secure them

## OPERATING INSTRUCTIONS

### RAISE

1. Check the jack for damage before each use.
2. Place the jack under the vehicle so that the lifting cylinder is directly under the vehicle's pick-up point. If necessary, fold the drawbar over by pulling the drawbar lever.
3. Secure the vehicle against rolling away. For this purpose, use wheel chocks and apply the handbrake of the vehicle.
4. Connect a compressor to the jack. Make sure that the connection is secured.
5. Turn the control lever clockwise to raise the lift cylinder.
6. Before the jack raises the vehicle, make sure the lift cylinder hits the vehicle's pickup point and cannot slip. Correct the position if necessary.
7. Raise the lifting cylinder completely.
8. Secure the vehicle with the aid of undercarriage blocks. Do not work under the vehicle while it is being lifted by the jack only.

### LOWERING

1. Get all items out from under the vehicle.
2. Remove the undercarriage blocks.
3. Carefully turn the control lever counterclockwise. Slowly lower the vehicle.
4. Once the lift cylinder is no longer touching the vehicle, you can fully depress the lever to lower the cylinder quickly.
5. Remove the wheel chocks.

## MAINTENANCE AND INSPECTION

- Joints and screws must be checked regularly.
- Lubricate all moving parts regularly.
- Only clean the jack with a dry cloth.
- Store the jack with the cylinder fully retracted.
- Change the hydraulic oil at regular intervals annually.

## TROUBLESHOOTING

Problem	Cause	Solution
Oil leaks at the bottom	Lubricating oil in the cylinder	Fill less hydraulic oil into the cylinder
	The jack has fallen over	Always put the jack down safely
Cylinder does not raise completely	Too little oil in the tank	Top up oil
Cylinder does not raise and lower slowly	Oil is too cold	Select oil for the appropriate ambient temperature
	The oil supply is broken	Repair the damage
	A steel ball (parts list no. 26) is loose	Replace this steel ball
Cylinder cannot be lowered again	Air pressure is too low	Air pressure should be higher than 0.8 Mpa
	The inlet hose or oil hose is kinked	Tighten the hose
The cylinder does not remain in the upper position	The steel balls are dirty	Clean the steel balls and put them back in place

PARTS LIST

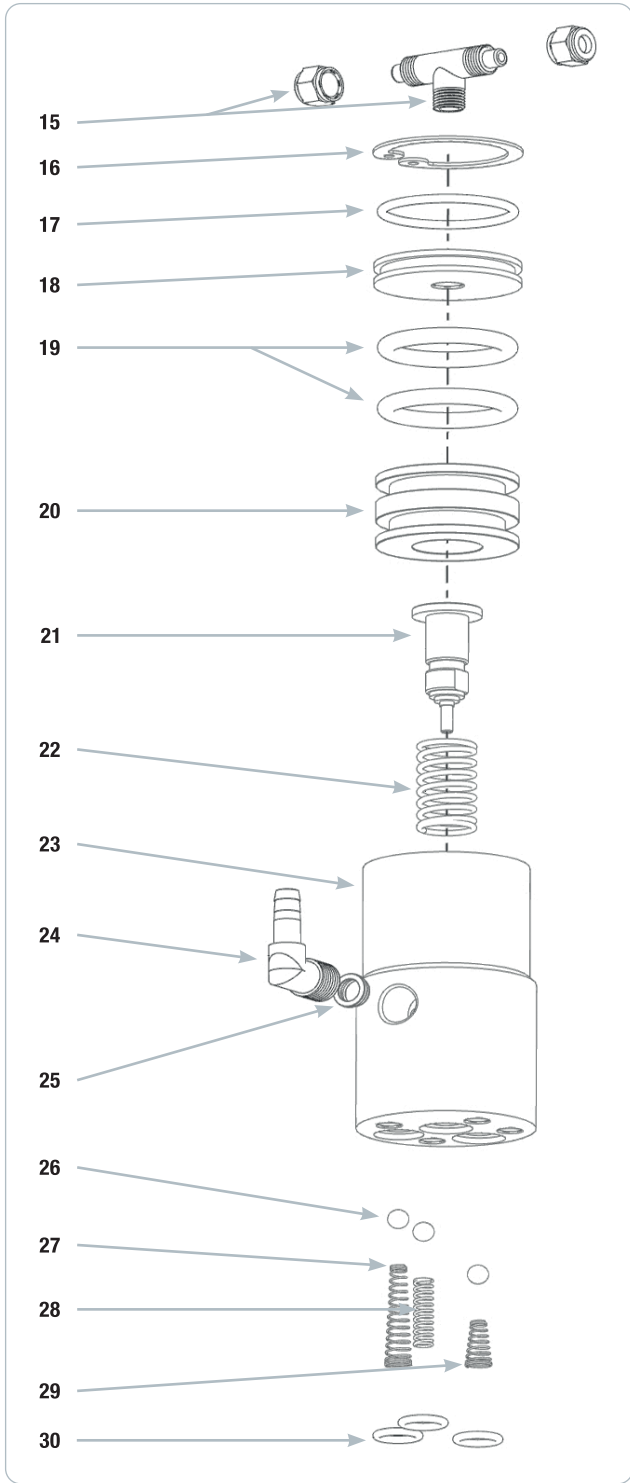
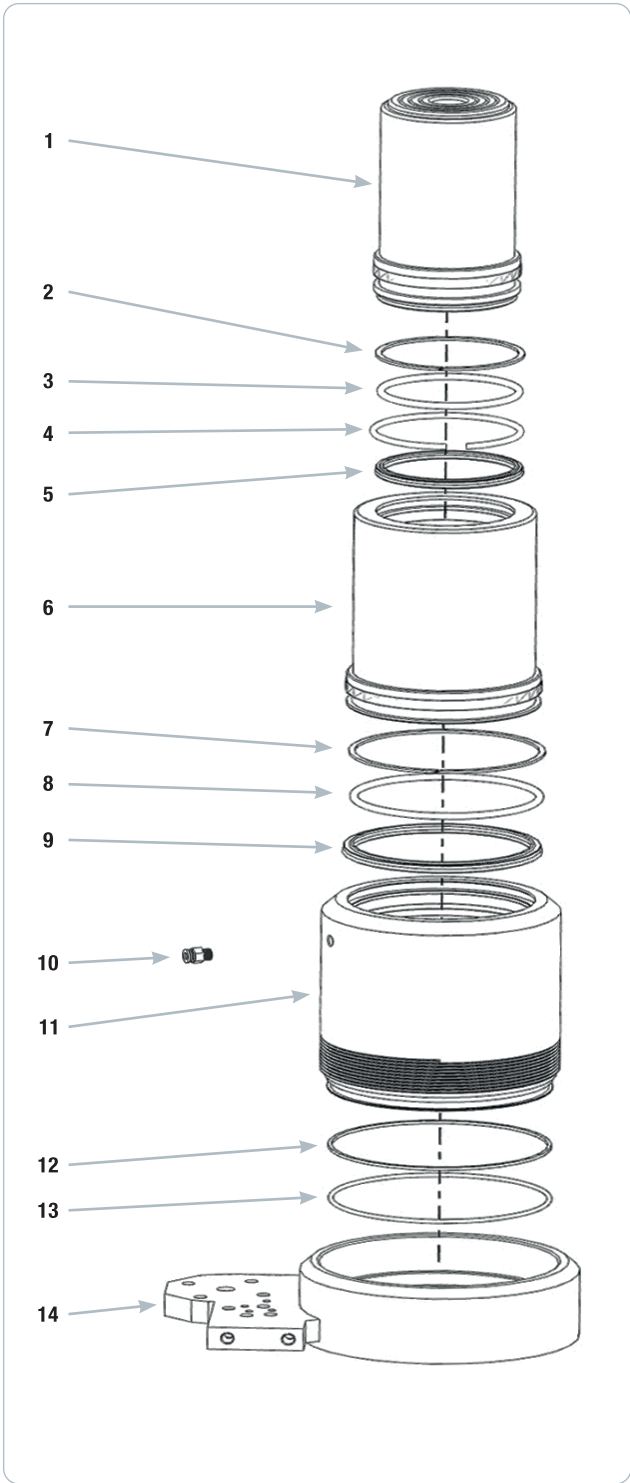

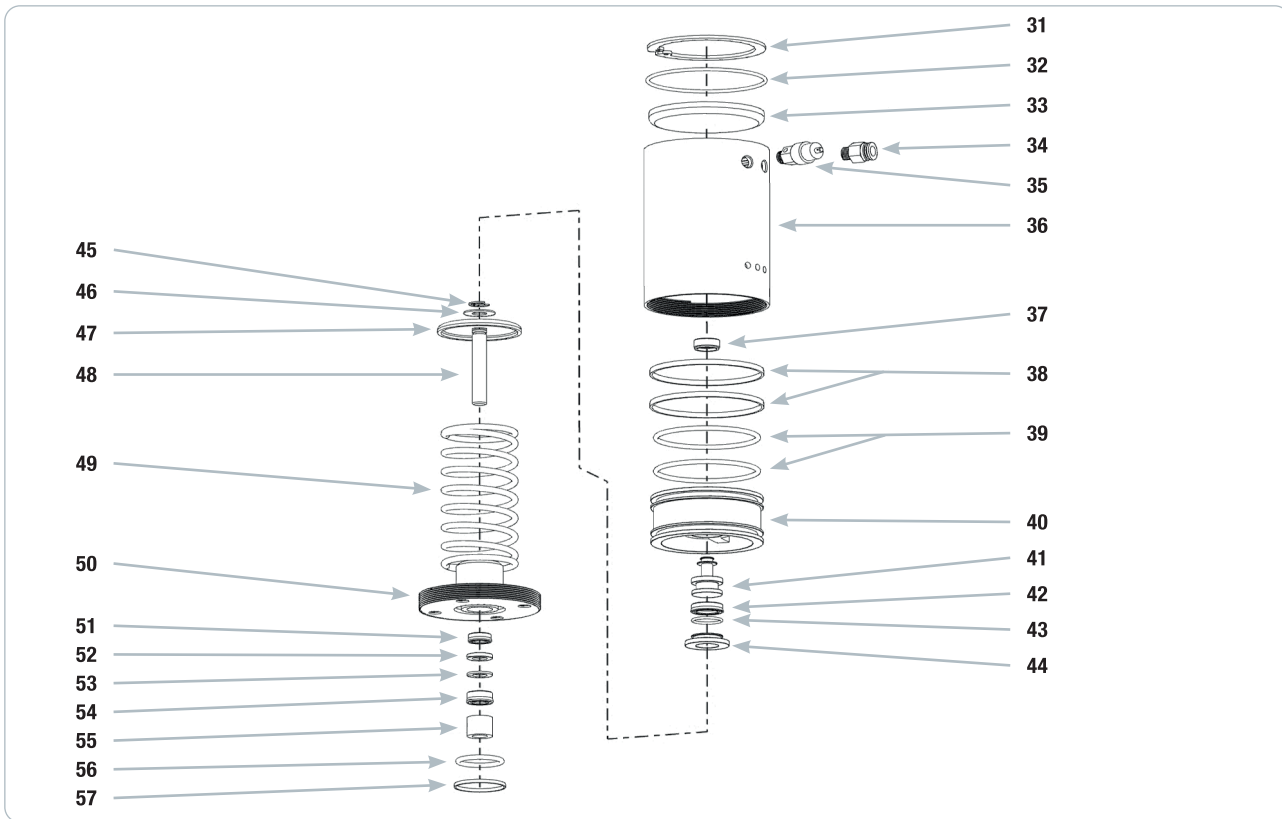

Number	Designation	Quantity
1	SM cylinder	1
2	Plastic ring	1
3	O-ring	1
4	Circlip	1
5	Oil seal	1
6	M-Cylinder	1
7	Plastic ring	1
8	O-ring	1
9	Oil seal	1
10	Hose nipple	1
11	B-cylinder	1
12	Fluorosilicone ring	1
13	O-ring	1
14	Base ring	1
15	Hose nipple	1
16	Circlip	1
17	O-ring	1
18	Sleeve cover	1
19	O-ring	2
20	Piston	1
21	Plunger	1
22	Spring	1
23	Valve body	1
24	Pagoda joint	1
25	Strainer	1
26	Steel ball	3
27	Spring	1
28	Spring	1
29	Spring	1

Number	Designation	Quantity
30	O-ring	3
31	Circlip	1
32	O-ring	1
33	Sleeve cover	1
34	Quick coupling	1
35	Safety valve	1
36	Cylinder	1
37	Rubber plug	1
38	Fluorosilicone ring	2
39	O-ring	2
40	Large piston	1
41	Small piston	1
42	Oil seal	1
43	O-ring	1
44	Sleeve cover	1
45	Circlip	1
46	Plate	1
47	Spring cover	1
48	Piston rod	1
49	Large piston	1
50	Cover	1
51	Oil seal	1
52	Steel plate	1
53	Plastic plate	1
54	Oil seal	1
55	Plastic plate	1
56	Oil seal	1
57	Fluorosilicone ring	1



## SERVICE & CONTACT

Contact our product experts and find help and solutions for your product. Here you will find all contact information listed by country and language: [www.topregal.us/en-us/service](http://www.topregal.us/en-us/service)

Responsible for the content:  
TOPREGAL US Corp.  
729 North Route 83, Suite 309  
Bensenville, IL 60106  
United States of America  
[www.topregal.us](http://www.topregal.us)

# EU Declaration of Conformity

The manufacturer

**TOPREGAL US Corp.  
729 North Route 83  
Suite 309  
60106 Bensenville, IL  
USA**

hereby declares that the following product

Product designation:

**TecMaschin  
Hydraulic jack for trucks**

Type:

**WH50**

Serial number:

**WH50-100000000-WH50-9999999999**

complies with all relevant provisions of the applicable legal regulations (hereinafter) - including their amendments in force at the time of the declaration. The sole responsibility for issuing this declaration of conformity lies with the manufacturer. This declaration refers only to the machine in the condition in which it was placed on the market; parts and / or interventions subsequently fitted by the end user are not taken into account.

Conforms to the provisions of the following European directives:

**2006/42/EC Machinery Directive**

Conforms to the provisions of the following standards:

**EN ISO 12100**

Name and address of the person who is authorized, compile the technical documentation:

TOPREGAL US Corp.  
729 North Route 83  
Suite 309  
60106 Bensenville, IL  
USA

Place: Bensenville  
Date: 08-20-2021



Juergen Effner  
Chief Executive Officer



**TECMASCHIN**