



OPERATING INSTRUCTIONS

Electric pallet straddle stacker

HE-S12/3



Please read this manual before using the product and follow the instructions it contains!

GENERAL

Foreword	3
Definitions	3
Safety instructions	4
Technical data	4
Overview of the main components	6
Safety devices and warning signs	7
Name plate	8
Pallet compatibility	8
Load chart	8
Operating instructions	9

MAINTENANCE

Regular inspections	12
Checklist for maintenance	12
Troubleshooting	14
In case of emergency	14
Service & contact	14
EU Declaration of Conformity	15

FOREWORD

Congratulations on the purchase of your new electric pallet straddle stacker. The HE-S12/3 has been manufactured from high quality materials specifically designed for long lasting and reliable use. For your own safety and to ensure correct operation of the electric stacker, be sure to read and follow these operating instructions before operating. Keep these operating instructions. Check the electric stacker for transport damage. Damaged lifting equipment must not be put into use. The HE-S12/3 is used to electrically raise and lower the transport load to the desired height. Improper handling may result in injury or damage to the unit. Any liability for damage resulting from improper use of the lifting device or failure to observe the instructions and rules of conduct in this operating manual is excluded. The operator is responsible for ensuring correct use by trained and authorised personnel only.

DEFINITIONS

AUTHORIZED PERSON

Trained and assigned personnel who use this machine, prepare it for use and provide appropriate, as well as sufficient, operator instruction. These instructions refer to:

1. Mechanics and auxiliary equipment of the device
2. Fluid quality maintenance and filter replacement
3. Protective devices
4. Causes and prevention of accidents

OPERATOR

Trained personnel authorized by the authorized person to use this machine for, among other things, safe use, setup, maintenance, cleaning, avoiding all hazards. Hazards include, but are not limited to, lifting and lowering, swinging out components, lifting too heavy loads, driving without sufficient visibility, and disregarding safe travel paths.

INTENDED USE

Use this machine in accordance with the information provided in these operating instructions.

DEVICE

This electric stacker.

PPE

Personal protective equipment, such as hard hats, safety glasses, hearing protection, safety shoes, protective gloves, protective clothing, etc.

REASONABLY FORESEEABLE MISAPPLICATION

Use of this equipment in a manner not intended by the constructor, but which may result from readily foreseeable human behaviour.

TARGET GROUP

Group of persons for whom these operating instructions are intended by the manufacturer (authorized representative, operator).

SAFETY INSTRUCTIONS

- Be sure to read the warning labels on the truck and the instructions in this manual before use.
- Do not operate the truck unless you are familiar with its functions and have received detailed instruction.
- Do not use the truck unless you have checked that it is in perfect condition. Pay particular attention to the chain, wheels, drawbar, chassis, control unit, mast, battery, etc.
- Do not use on heavily soiled floors or in explosive environments.
- Use only on level ground. Do not carry out work on slopes.
- It is forbidden to carry people on the forks.
- When lifting the fork, make sure that no one is standing or walking under the forks.
- Wear gloves when using the pallet stacker.
- Do not transport goods at a height above 12". The heights above 12" are exclusively for storing and retrieving goods.
- Maintain a safety distance of 24" when transporting / lifting goods.
- Always distribute the weight of the goods evenly on both forks. Never use only one fork. The centre of gravity of the goods should be in the middle of the two forks.
- Observe the goods during transport. If the goods become unstable and threaten to fall / tip, stop the operation immediately with the emergency stop button.
- Do not load beyond the maximum capacity.
- Operation must take place in at least 50 lux lighting.
- Suitable for indoor operation at a room temperature between 41 °F and 104 °F.
- Carry out maintenance according to the regular inspection.
- Charging the battery should be done in a dry and ventilated place, away from open fire.
- Comply with country-specific standards and regulations.
- Do not modify the pallet stacker, without a written consent of the manufacturer.
- Without specific training and express authorization the operator is not allowed to perform any repairs on the pallet stacker. Under no circumstances must the driver change the setting of switches or safety installations or render them ineffective.
- Modifications and changes to the device not approved by the manufacturer will void the warranty.

TECHNICAL DATA

GENERAL

Type	Unit	Value
Brand		SolidHub
Model		HE-S12/3
Rated traction weight	lbs	2645.55
Load center	"	23.62
Min. lifting height	"	3.1
Max. lifting height	"	118.11
Capacity at max. lifting height	lbs	2645.55
Net weight with battery	lbs	1324.98
Wheelbase	"	51.18
Controller		CURTIS

PERFORMANCE

Type	Unit	Value
Travel speed, loaded / unloaded	mph	2.8 / 2.92
Lifting speed, loaded / unloaded	"/s	4.53 / 6.3
Lowering speed, loaded / unloaded	"/s	6.69 / 5.12
Max. gradeability, loaded / unloaded	%	5 / 7
Service break		Electromagnetic

DIMENSIONS

Type	Unit	Value
Height (retracted mast)	"	87.4
Height of mast, extended	"	152.76
Overall length	"	73
Axle center to forkface	"	26.38
Overall width	"	44.5 - 57
Track width	"	38 - 50
Fork width	"	3.94
Fork length	"	46.85
Fork height	"	1.57
Outer width of fork	"	29.5
Distance between fork arms	"	43.7
Battery dimensions	"	10.32 x 6.77 x 6.69
Min. ground clearance	"	1.18
Aisle width with pallet 39.37 x 47.24 across forks	"	87.4
Aisle width with pallet 31.5 x 47.24 along forks	"	90.35
Min. turning radius	"	66.92

ENGINE

Type	Unit	Value
Drive engine	kW	0.75
Lift engine	kW	2.2
Rated voltage	V	24
Rated capacity	Ah	75

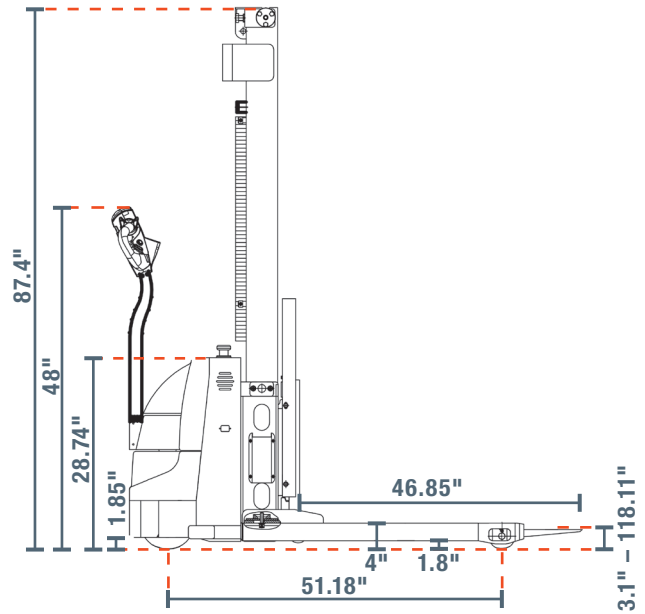
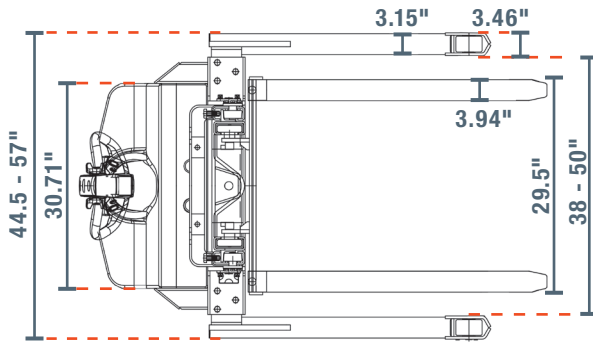

OVERVIEW OF THE MAIN COMPONENTS

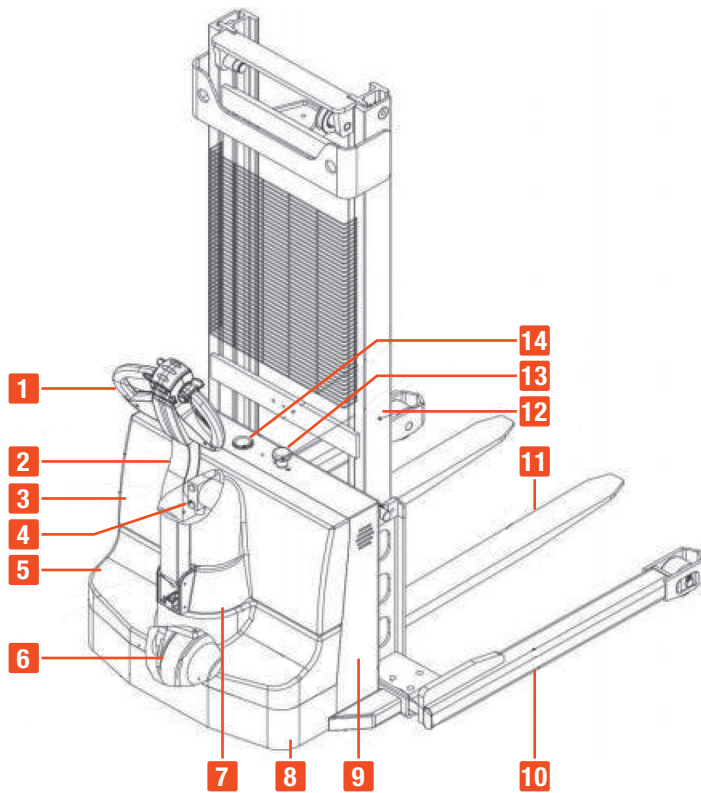

Nr.	Designation
1	Handle
2	Handle Rod
3	Cover
4	Hydraulic Pump
5	Cover
6	Drive Wheel
7	Balance Wheel
8	Cover
9	Rear Body
10	Support Leg
11	Fork
12	Mast
13	Emergency Stop Button
14	Battery Indicator

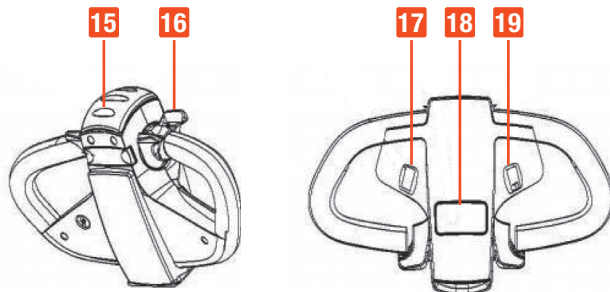

Nr.	Designation	Function
15	Collision Switch	Safety function which, when activated, forces the truck to reverse until the switch restored to neutral
16	Travel Switch	Controls the driving speed and direction
17	„Lower“ Button	Lowers fork
18	„Lift“ Button	Raises fork frame
19	Warning Signal Button	Triggers a warning signal

SAFETY DEVICES AND WARNING SIGNS

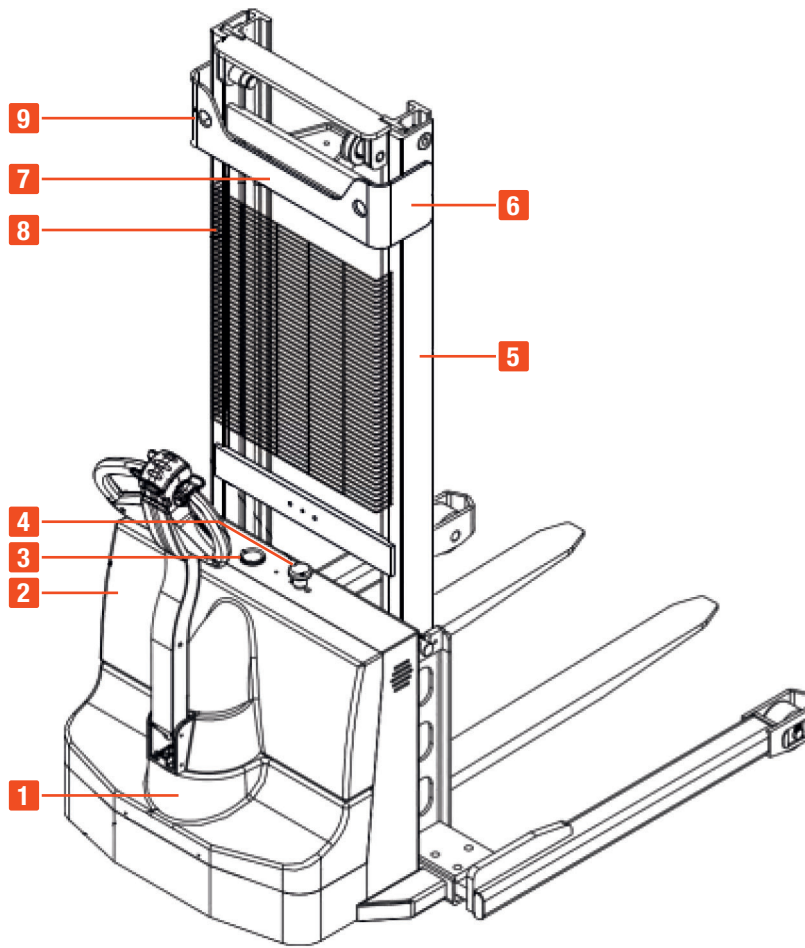

Nr.	Warning Sign
1	
2	<p>WARNING</p> <p>Breaking these rules may cause serious or fatal injuries.</p> <p>Read and understand all warnings and operation instructions to operator. Always follow operating instructions. Only trained and authorized operator can operate this truck.</p> <p>You should shut off key switch and pull off the plug before service, except when trouble shooting.</p> <p>Close the electric part with compress air. No water. Do not splash your hands, face or any part of body.</p> <p>Use the plug.</p> <p>Check truck condition before operating the machine.</p> <p>Operator must wear protective belts, adjust the safety device's head enough to support the truck.</p> <p>Be careful to control the truck's speed.</p> <p>Always make sure not to step on the feet when you walk on the truck.</p> <p>Always make sure when load interference with stability, travel with load trailing.</p> <p>When other service area is off, do not get back on the special care when truck, when in service, when slowly, do not step on truck.</p> <p>The transport pallet should always be transported at low height to avoid any accident.</p> <p>Never place any part of your body over the mast structure or between the mast of truck.</p> <p>Do not carry passengers.</p> <p>Close doors and avoid them at cross aisles and whenever when to intersect.</p> <p>Always stop, stand, clear and brake correctly.</p> <p>Steer down loaded when make turns and an entrance ground.</p> <p>Do not allow anyone to stand or pass under load or off the load carrier.</p>
3	

Nr.	Warning Sign
4	
5	<p>WARNING</p>
6	

Nr.	Warning Sign
7	
8	<p>WARNING</p>
9	

NAME PLATE

Electric forklift

Serial number	HE-S12/3
Serial No.	HE-S12/3- <input style="width: 80px;" type="text"/>
Article No.	222027-US
Year of Manufacture	<input style="width: 80px;" type="text"/>
Max. Load	2645 lbs
Max. Lifting Height	118"
Battery Capacity	75 Ah

TOPREGAL US Corp., 729 North Route 83 Suite 309, Bensenville, IL 60106

LOAD CHART

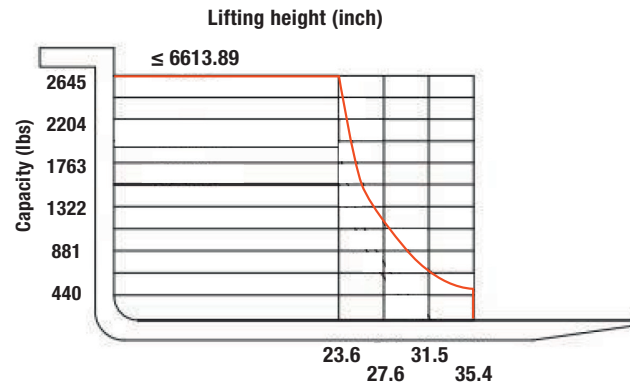

The load chart shows a given load centre C [inch], the horizontal load capacity of the largest load Q [lbs] and the lifting height H [inch] corresponding to the vehicle.

PALLET COMPATIBILITY



HE-S12/3

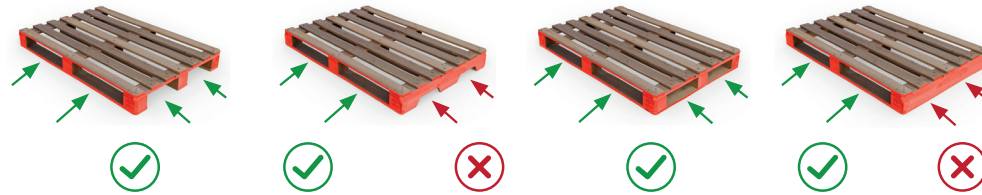

i Please make sure that the dimensions of the pallet match the electric walkie straddle stacker.



HE1200/3



i The pallet must be completely open in one direction. Please also make sure that the dimensions of the pallet match the dimensions of the electric walkie stacker because the forks and legs are not adjustable.

OPERATING INSTRUCTIONS

STARTING

When operating this truck, please observe the warning and safety instructions. Make a visual inspection for damages of the whole truck (especially tyres and load carrying devices) as well as of the battery fixing and the cable connections.

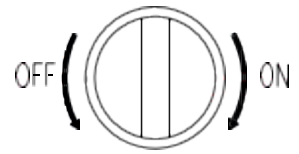

Make sure that you always look in the direction of travel and that no goods or objects obstruct or restrict your view. Ensure that goods are placed stably and securely in the centre of the forks for transport. To start pull out the emergency stop button and turn the key clockwise to the ON position. Make sure that nobody is in the danger area. Press the horn (19) to start the signal tone and check the function of the drawbar and the battery capacity.

CONTROL

Start the truck, move the tiller to a tilted position **S** or **K**. Operate the direction lever on the handle: Forward **V** or Reverse **R**. By carefully moving the direction lever, you control the speed until the desired speed is reached. Position the direction lever in the centre to slow the truck to a complete stop / parking position. When the vehicle is permanently stopped, apply the parking brake. Always drive carefully and keep an eye on the roads – regulate the speed if necessary.

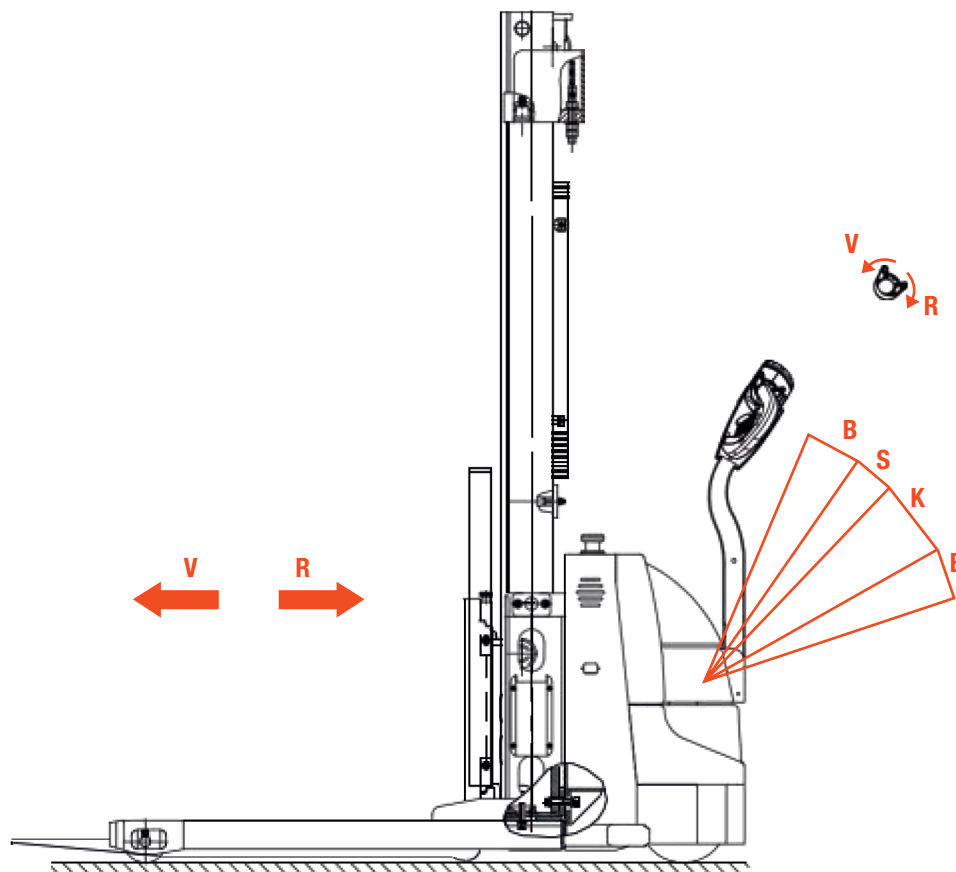

LIFTING LOADS

Never load the truck beyond the specified capacity. The maximum load capacity of this high lift truck is 2645.55 lbs. Place the fork completely under the goods to be lifted and operate the lift button until the goods have reached the desired lift height.

LOWERING LOADS

Carefully press the down button and observe the goods. As soon as the weight has been reduced and the pallet is secure, carefully pull out the forks.

PARKING

Never park the truck on a slope or sloping terrain! This truck is equipped with an electromagnetic parking brake. Always set the forks to the lowest position when not in use and park the truck in a safe area. Turn the key anticlockwise to the OFF position and remove the key. Push the emergency stop button to disconnect the device from the power supply.

APPLYING BRAKES

The performance of the load braking system depends on the ground conditions and the load of the truck. Activate the brake function as followed:

- By moving the directional lever back to the position **0** or by releasing this lever the vehicle brake is activated.
- Or by moving the direction lever in the opposite direction until it starts to move in the other direction.
- When the drawbar is moved up or down into braking zone **B**, the vehicle braking is activated.
- When the emergency stop switch is actuated, the handle is automatically brought into the braking zone and the parking brake is activated.
- By means of the belly switch at the head of the drawbar, this function can also be triggered with the upper body.
- The truck slows down and comes to a standstill up to reverse **R**.

ADJUSTING THE SUPPORT LEGS

1. Remove the 3 bolts with a 15/16 inch open-end wrench or a ratchet.
2. Lift the straddle stacker with another lifting device at the lifting points (9).
3. Pull the support leg (10) out of the bracket. Make sure you can match 3 screw holes.
4. Re-torque the bolts into the bolt holes using a 15/16 inch open-end wrench or ratchet.
5. Set the stacker down again.

CHARGING THE BATTERY

- Only qualified personnel should carry out battery repair. Follow the instructions in the user manual.
- Battery recycling must comply with government laws and regulations.
- Improper handling, e.g. use near fire or gas, can cause an explosion! The storage of flammable materials or flammable liquids is prohibited in the battery charging area. Smoking is prohibited and the area must be well ventilated.
- Before charging or installing the battery, park the truck safely (parking position).
- Carry out maintenance work before connecting the wiring harness correctly and trouble-free to other parts of the vehicle.
- Only the use of the sealed lead-acid battery is permitted, the additional battery weight has an influence on the behaviour of the vehicle.

INSTRUCTIONS

1. Remove the battery plug.
2. Connect the battery plug with the charging lead of the stationary charger.
3. Turn on the charger. While charging the stacker the LED lamp glows red. As soon as it's fully loaded it switches to green.

BATTERY REMOVAL

Park the truck securely and turn off the power before removal and installation battery. Battery removal and installation steps:

- a:** Remove screws (1), take out the side plate (2&3).
- b:** Remove battery cables.
- c:** Put battery in.

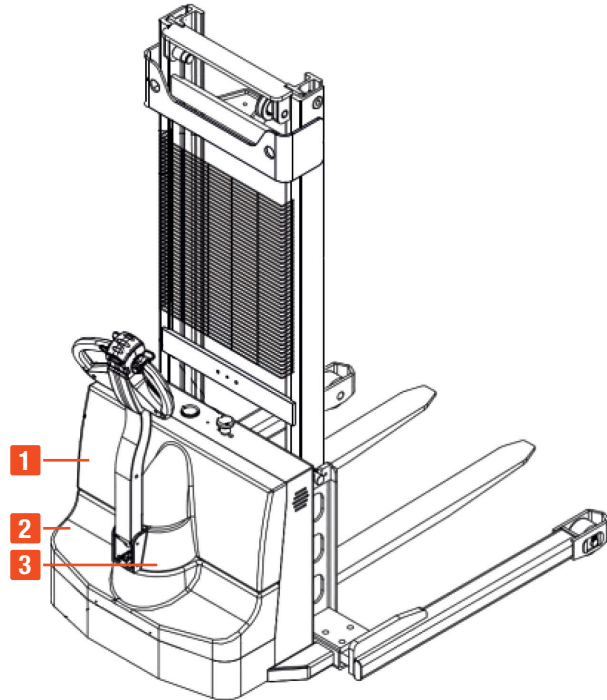

INDICATORS

1. LED, Indicating the remaining capacity of the battery.
2. The hours of operation that truck has already performed. 0.0~99999.0(h).

The indicator will display the charging capacity of the battery when the key switch is turned on. Every column means 10 %.

After approximately 3.5 hours (normal load) the battery of the electric truck must be charged. Charge the battery only in well ventilated areas. When charging is complete, disconnect the plug from the mains and store it safely in the in the chassis. When the battery is completely discharged, the charging process takes approx. 7.5 hours. Avoid discharging the battery of more than 80 % of the charging capacity to ensure a long battery life.

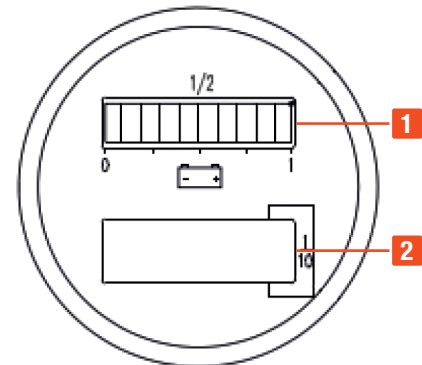

REPLACING THE BATTERY

Park the truck securely and turn off the power before removal and installation battery. Push the emergency stop button, to make sure, that no more electric current flows.

Battery removal and installation steps:

1. Remove the eight screws from the cover and take out the side plate.
2. Remove the battery cables. Only try to remove the battery, when you've made sure that every cable has been removed.
3. Lift the battery out of the housing, with another lifting device.
4. Put a new battery in the housing and process the former steps in reverse order.



Please observe the maximum operating temperature of the battery.

REGULAR INSPECTIONS

The respective inspection points (plus equipment identification) for the periodic inspections/thorough examinations are to be checked in an integrated manner in the associated inspection report of the lifting equipment, taking into account the mandatory fulfilment of the Lifting Operations and Lifting Equipment Regulations 1998 (LOLER). (Recommendation: FEM4.004)

CHECKLIST FOR MAINTENANCE

The following servicing checklist indicates the operations to be performed and the respective intervals to be observed. The following maintenance intervals are defined:

- **W** = Every 50 operating hours, at least, however, once a week
- **A** = Every 250 operating hours
- **B** = Every 500 operating hours, or at least annually
- **C** = Every 2000 operating hours, or at least annually

The W maintenance intervals must be carried out by the operator / customer. After operating for about 100 hours, the operators have to check the nuts and bolts if they are loosened and tighten them if required.

System / Component	Procedure	Maintenance interval			
		W	A	B	C
Braking	Check magnetic brake air gap			•	
Electrical system	Test instruments, displays and control switches	•			
	Test warning and safety device		•		
	Make sure wire connections are secure and check for damage			•	
	Test micro switch setting	•			
	Check relays			•	
	Fix the motor and cable			•	
Power supply	Visually inspect battery		•		
	Visually inspect battery plug			•	
	Check battery cable connections are secure, grease terminals if necessary			•	
Travel	Check the transmission for noise and leakage			•	
	Check travel mechanism, adjust and lubricate if necessary.		•		
	Check control handle recuperating function				
	Check wheels for wear and damage			•	
Truck frame	Check wheel bearings and attachments			•	
	Check truck frame for damage			•	
	Check labels are present and complete			•	
	Check mast attachment			•	
Hydraulic operations	Test hydraulic system		•		
	Check that hose and pipe lines and their connections are secure, check for leaks and damage		•		
	Check cylinders and piston rods for damage and leaks and make sure they are secure			•	
	Check load chain setting and tension if necessary			•	
	Visually inspect mast rollers and check contact surface wear level			•	
	Check forks, load handler for wear and damage			•	
	Check hydraulic oil level			•	
	Replace hydraulic oil				•
Check and clean hydraulic oil filter. Replace it if necessary				•	

CHECK HYDRAULIC OIL LEVEL

1. Prepare the truck for servicing and maintenance operation.
2. Remove the hood.
3. Check the hydraulic oil level of the hydraulic tank. There are markings on the hydraulic tank. The oil level must be checked with the lifting device being lowered. If required, top up with hydraulic oil with the required characteristics.

CHECK THE TRANSMISSION OIL LEVEL

1. Prepare the truck for servicing and maintenance operations.
2. Remove the hood. Turn the control shaft to the switch-off position on the right side. Check gear-oil level, oil level must reach the checking screw. If required, top up with gear oil with the required characteristics.

Code	Description	Used for
A	HM46#	Hydraulic system
B	GL-85W-90	Gear case

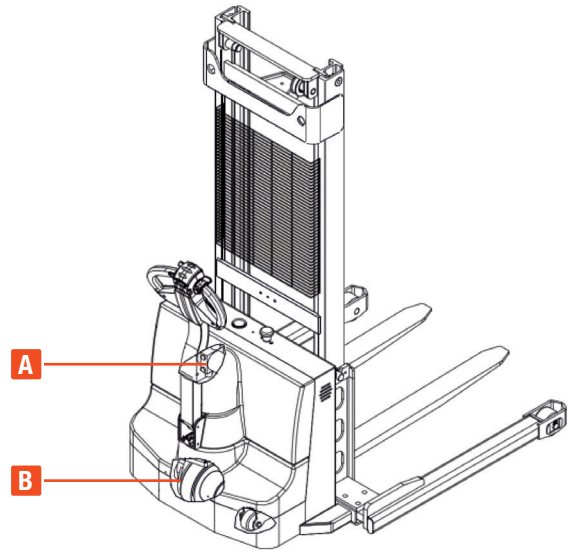

TROUBLESHOOTING

If there is a fault and / or the truck does not work, please stop using the truck and press the emergency stop button. Park in a safe area, turn the key switch anticlockwise and remove the key. Immediately inform the responsible employee and / or contact the customer service.

Problem	Cause	Solution
The forks cannot be lifted to the maximum height	Max. capacity exceeded	Never exceed the maximum capacity
	Battery is discharged (lower than 40 %)	Check the battery and recharge it
	The fuse is off	Check and replace the fuse
	The hydraulic oil is not sufficient	Check and, if necessary, top up the hydraulic oil
	The oil pressure is too low; oil leaks	Check and if necessary replace sealing hoses and / or cylinders
The forks cannot be lowered	Locking valve is dirty / blocked	Check the hydraulic oil and control valve. Change the hydraulic oil if necessary
	Electromagnetic valve opens or is damaged	Check or replace solenoid valve
The stacker does not react	The battery is charging	When the battery is fully charged, unplug the truck
	The battery is not connected	Connect the battery correctly to the charger
	The fuse is off	Check and possibly replace the fuse
	Battery is too weak	Check the battery and recharge it
	Check the battery and recharge it	Pull out the emergency stop switch
The drawbar is not in the correct position	Move the drawbar out of the braking zone	
Forklift only moves in one direction	Accelerator / connections are damaged	Check the accelerator and the connection
Stacker runs very slow	Battery is too weak	Check the battery charge level and recharge it
	The electromagnetic brake is activated	Release the electromagnetic brake
	The tiller is not connected properly or cable is damaged	Check the wiring
The stacker starts suddenly	Damage to the control unit	Replace the control unit
	The accelerator does not return to the centre position	Repair or replace the accelerator

IN CASE OF EMERGENCY

In an emergency, press the emergency stop button. All electrical functions are stopped. Keep a safe distance. Inform the authorized person and / or contact the customer service.

SERVICE & CONTACT

Contact our product experts and find help and solutions for your product. Here you will find all contact information listed by country and language: www.topregal.us/en-us/service

Responsible for the content:
 TOPREGAL US Corp.
 729 North Route 83, Suite 309
 Bensenville, IL 60106
 United States of America
www.topregal.us

EU Declaration of Conformity

The manufacturer

TOPREGAL US Corp.
729 North Route 83
Suite 309
60106 Bensenville, IL
USA

hereby declares that the following product

Product designation:
SolidHub electric pallet
straddle stacker

Type:
HE-S12/3 , lifting height 118.11
in, WLL 2,646 lbs

Serial number:

HE-S12-3-1000000000-HE-S12-3-9999999999

complies with all relevant provisions of the applicable legal regulations (hereinafter) - including their amendments in force at the time of the declaration. The sole responsibility for issuing this declaration of conformity lies with the manufacturer. This declaration refers only to the machine in the condition in which it was placed on the market; parts and / or interventions subsequently fitted by the end user are not taken into account.

Conforms to the provisions of the following European directives:
2006/42/EC Machinery Directive

Conforms to the provisions of the following standards:

EN ISO 12100
EN ISO 3691-1
EN 16307-1
EN 1175
EN 12053
EN 13059

Name and address of the person who is authorized, compile the technical documentation:

TOPREGAL US Corp.
729 North Route 83
Suite 309
60106 Bensenville, IL
USA



Place: Bensville
Date: 12-22-2022

Juergen Effner
Chief Executive Officer

SolidHub