

## ROLLER CONVEYOR FRB-P5, FRB-S5 / SKATEWHEEL CONVEYOR FRB-PK7, FRB-SK7

### FEATURES

- Optimal solution for an inexpensive and flexible entry into conveyor technology without a drive.
- Ideal for incoming and outgoing goods where space is limited or no fixed conveyor lines can be installed.
- Small dimensions when pushed together for optimal storage.
- Particularly flexible handling thanks to fixed and swivel castors with brakes for quick and safe locking.
- Stepless height adjustment of the telescopic legs from 700 to 1000 mm for perfect alignment on sloping surfaces.

### GENERAL

Type	Unit	FRB-P5	FRB-S5	FRB-PK7	FRB-SK7
Total width	mm	750			
Overall length (retracted)	mm	1920	2040	2220	
Overall length (extended)	mm	4700		6900	
Height	mm	700 - 1000			
Web width	mm	600		614	
Weight	kg	97	117	125	146
Load capacity	kg/m	40			
Curve inner radius	mm	600			
Number of axles		5		7	
Material frame		3 mm carbon steel powder-coated			
Material of supports		Galvanised steel			

### ROLLS

Type	unit	FRB-P5	FRB-S5	FRB-PK7	FRB-SK7
Material		PVC	Galvanised steel	ABS	Galvanised steel
Diameter	mm	50		48	50
Length roll	mm	253	500	16	22
Max. distance between rolls	mm	70			
Number of rolls per row		2	1	6	

### WHEELS

Type	unit	FRB-P5	FRB-S5	FRB-PK7	FRB-SK7
Diameter	mm	100			
Material		Rubber			
Quantity (without / with brakes)		4 / 6		6 / 8	

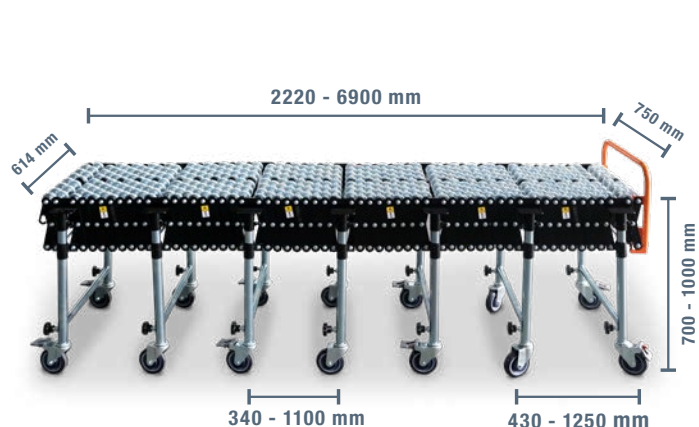

Measurements skatewheel conveyor

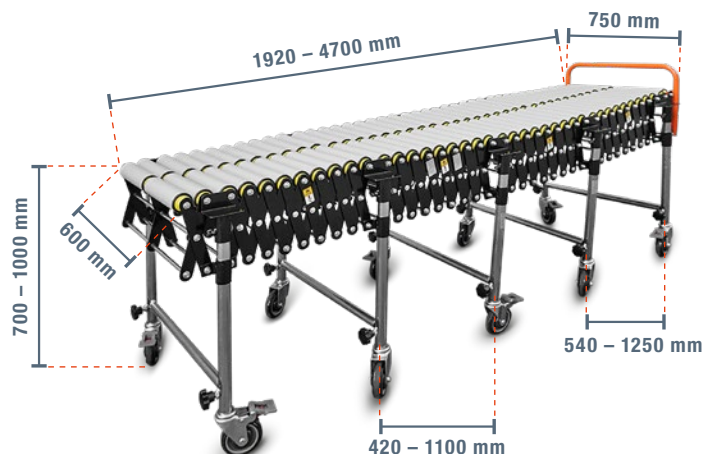

Measurements roller conveyor